

RANCHO

PERFORMANCE-TRANSAXLES



WWW.RANCHOPERFORMANCETRANS.COM



For nearly 3 decades RANCHO PERFORMANCE TRANSAXLES has been providing the Volkswagen, Sand Sports and Off Road Motorsports industries with the strongest, most reliable, highest quality transaxle assemblies available. Cutting edge research and development combined with rigorous real world testing allow us to provide professionals and home builders alike with a winning combination for unparalleled performance and reliability.

Rancho's heavy involvement in and backing of competitors in all classes of drag racing provide racers with transmissions that can take the brutal forces they are subjects to every time they launch. It also provides Rancho technicians with a unique test bed and source for valuable insight. If we can provide an unbeatable set up for the world's fastest and quickest drag cars we can certainly cover your needs.

Transmissions for long travel sport buggies, extreme use sand, off road vehicles and the most sophisticated off road race machines are our specialty. These monster vehicles require nothing short of maximum strength, durability and reliability. Once again you'll find Rancho Competition, Extreme Duty and Mendeola transaxles in machines that keep on running. Rancho is also the world's largest and most sought after source for off the shelf and ground up custom designed and fabricated Mendeola Transaxles. If you need a Mendeola you need to visit Rancho and we'll design one that can handle your power and use.

Major retailers, restoration facilities, service and VW specialty shops from Japan to Australia, Puerto Rico to Alaska and everywhere in between choose Rancho products based on their proven reliability, ability to deliver on a timely basis and no BS factory support. They know if there is a problem all they have to do is call our number. Problem solved.

No matter if you're building a Total Restoration, Daily Driver, Street Cruiser, Weekend Warrior, Drag Car, Sand Toy or Baja Basher, Rancho is here to provide the most experienced advice, responsive service and of course the best performance transmission technology money can buy. We ship via UPS around the world daily and accept Visa and MasterCard for you convenience. Call in your order or send us a FAX. Either way your transaxle order will be handled immediately and built to your specifications and requirements.

If you're in the area stop by our new state-of-the art 14,000 sq facility. Opened in early 2007 the New Rancho World Headquarters features complete design, machine shop, custom fabrication and assembly capabilities not to mention a "we've got it" parts department all under one roof. We do-it-all on the premises and you're welcome to stop by and browse through our educational and thought provoking show room.

Special thanks to the following for photography contributions: RK Smith/Dune Buggies and Hot VWs, Brian Watts, West Coast Classics, Suspensions Unlimited, Sand Cars Unlimited, McKenzie's Performance, Kinkade Racing, Steve Weidner, Bob Clark. Production Extreme Marketing

RANCHO PERFORMANCE TRANSAXLES
1015 East Elm Ave
Fullerton, CA 92831

ORDERS:
PHONE: 714-680-6737
FAX: 714-680-3110

WWW.RANCHOPERFORMANCETRANS.COM

WE'RE GEARED FOR SERVICE



TOLL FREE 800-304-8726

TYPE 1 & 3 TRANSAXLES



**1960 AND EARLIER
SPLIT CASE
SWING AXLE
(WITH AXLES)**

61-66 6V SWING AXLE

67-68 12V SWING AXLE

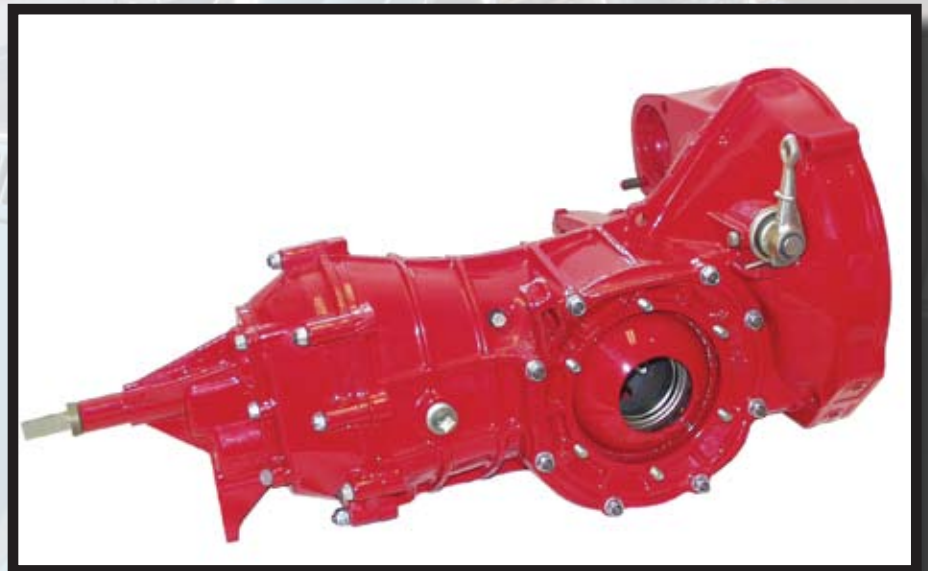

69-70 12V IRS TRANS

71-72 12V IRS TRANS

73-LATER 12V IRS TRANS

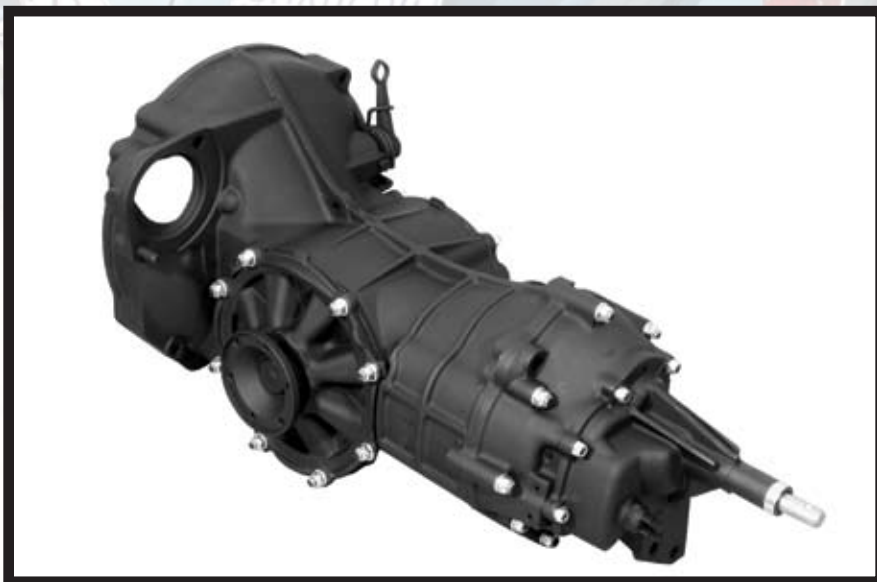

TYPE 2 BUS TRANSAXLES

**60-EARLIER SPLIT CASE
WITH REDUCTION BOXES**

**61-66 6-V SWING BUS W/O
REDUCTION BOXES**

**67 12V SWING BUS W/O
REDUCTION BOXES**

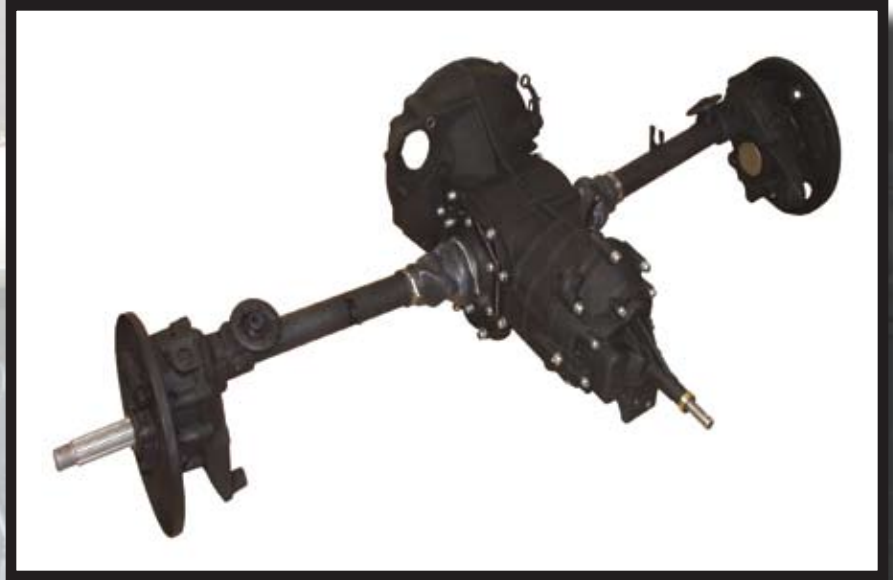

**68-70 IRS BUS (EARLY
STYLE T/O FORK)**

**71 IRS BUS (LATE STYLE
T/O FORK NO HANGERS)**

**72-75 IRS BUS (LATE STYLE
T/O FORK W/HANGERS)**

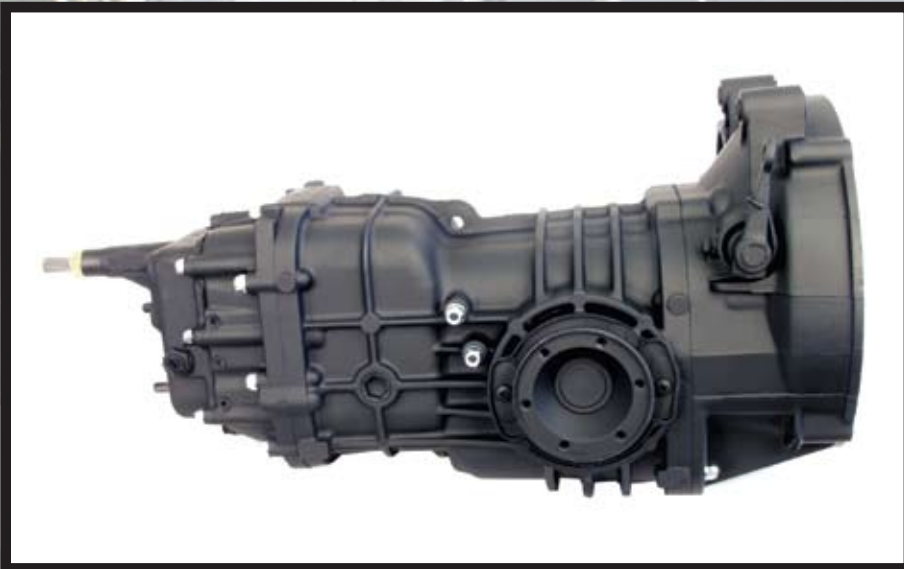

**76-79 IRS BUS
091 BELL HOUSING**

**80-82 IRS BUS
(AIR COOLED VANAGON)**

**83-LATER IRS BUS (WATER
COOLED VANAGON)**



TOLL FREE 800-304-8726

PRO-STREET SWING-IRS



PRO-STREET SWING-IRS

**4-SPIDER SUPER DIFF
H/D ALUMINUM SIDE COVERS
WELDED 3-4 HUBS
STEEL SHIFT FORKS
HARDENED KEYS
WELDED T/O SHAFT**

PRO-STREET PLUS

**SAME AS ABOVE PLUS:
3:78 1ST GEAR SET
4:12K RING & PINION
C/M PINION PLATE OR NUT
SWING AXLE (SWAY-A-WAY)
IRS (SUPER SPLINES WITH
BUS C/V FLANGES)**

**3.88 RING & PINION UPGRADE
ALL TYPE 1, II THROUGH 67 &
TYPE 3 TRANSAXLES**

WWW.RANCHOPERFORMANCETRANS.COM

PRO-COMP SWING-IRS



PRO-COMP SWING -IRS

**4 SPIDER SUPER DIFF
H/D ALUMINUM SIDE COVER
WELDED 3-4 HUBS
STEEL SHIFT FORKS
HARDENED KEYS
WELDED T/O SHAFT
CLOSE RATIO GEAR SETS:
1.48, 1.58, 1.70 3RDS & 1.04, 1.14,
1.21, 1.31 1.43 4THS**

PRO-COMP PLUS

**SAME AS PRO-COMP
WITH CLOSE RATIO
3-4 GEAR SETS
3RD GEAR SETS:
1.48-1.58-1.70
4TH GEAR SETS:
1.04-1.14-1.21-1.31-1.43**

TOLL FREE 800-304-8726

PRO-SAND TYPE 1 SWING-IRS

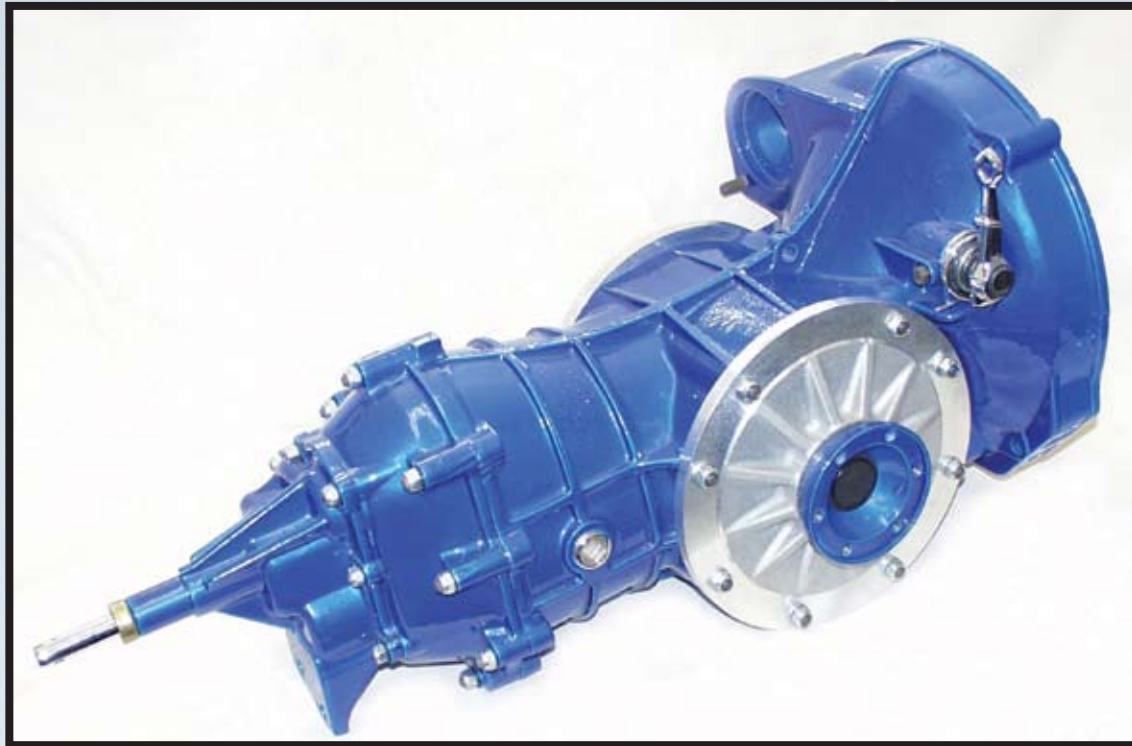

PRO SAND SWING OR IRS

RICHMOND GEAR 4.86 RING AND PINION

4 SPIDER SUPER DIFF

H/D ALUMINUM SIDE COVER

WELDED 3-4 HUBS

STEEL SHIFT FORKS

HARDENED KEYS

WELDED T/O SHAFT

CLOSE RATIO GEAR SETS:

1.48, 1.58, 1.70 3rd

1.04, 1.14, 1.21, 1.31 1.43 4th

OPTIONAL POWDER COAT FINISH

AVAILABLE ON ALL TRANSMISSIONS

IN A WIDE VARIETY OF COLORS

OPTIONAL FULL or PARTIAL POLISH

AVAILABLE ON ALL TRANSMISSIONS

PRO-BUS 002-091

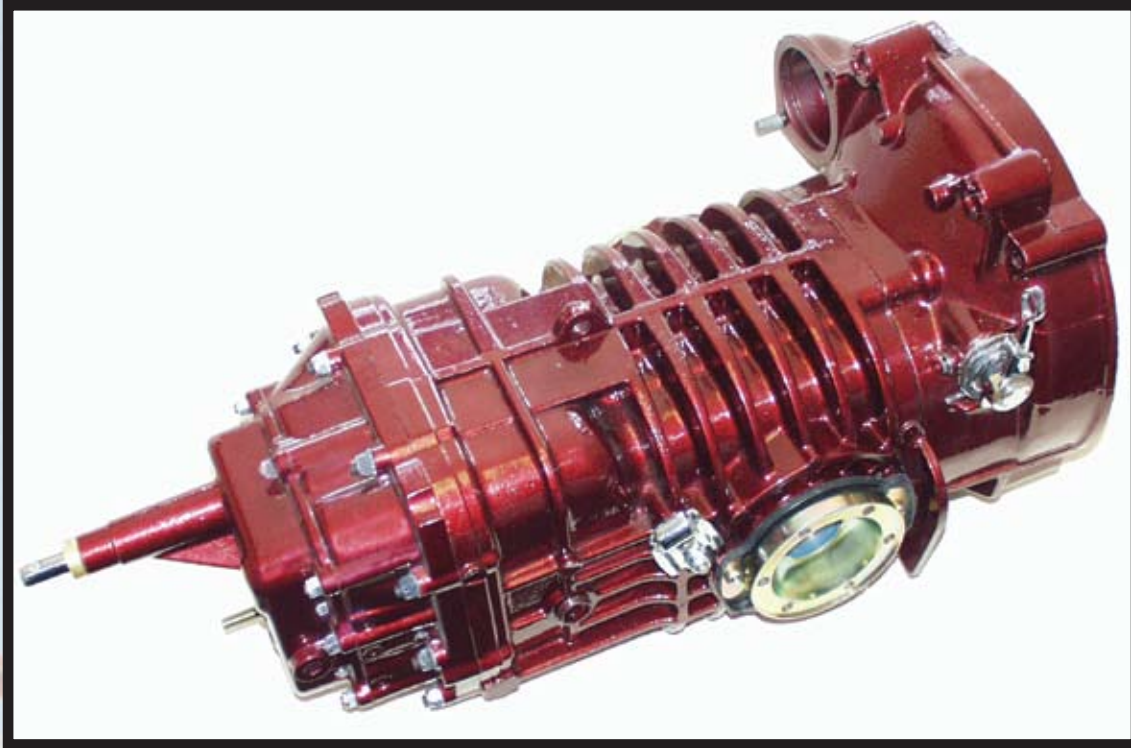

PRO IRS BUS 002 STYLE

5.38 RING AND PINION RATIO

CLOSE RATIO 3-4 GEAR SETS

1.48, 1.58, 1.70 3rd

1.04, 1.14, 1.21, 1.31, 1.43 4th

WELDED 3-4 GEAR HUBS

HARDENED KEYS

GUSSET SHIFT BRACKET

STEEL SHIFT BALL

PRO IRS BUS 091 STYLE

4.57 RING AND PINION RATIO

WEDDLE GEAR SETS 1ST THRU 4TH

SUPER DIFF

CHROMEMOLY DIFF COVER

CHROMEMOLY PINION NUT

CASE GUSSETS

CRO-MOLY 930 C.V. FLANGES

TOLL FREE 800-304-8726

PRO-DRAG/PRO-DRAG 002 BUS



PRO DRAG SWING AXLE

**3:88-4:12-4:37 RING & PINION
WEDDLE 1st - 4th GEARS
SYNCROS OR PRO_RINGS
HD SIDE COVER & SPOOL
WELDED T/O SHAFT
C/M PINION BEARING OR PLATE/NUT
GUSSETED TRANSMISSION CASE
SWAY-A-WAY AXLES
TIMKEN BEARING ON PINION SHAFT**

PRO DRAG 002 BUS

**4:57-4:86 RING & PINION
WEDDLE 1st -4th GEARS
SYNCROS OR PRO RINGS
ALUMINUM SPOOL
WELDED T/O SHAFT
C/M PINION BEARING NUT
GUSSETED TRANSMISSION CASE
FOLTS SWING AXLE CONVERSION**

MENDEOLA MD4-DRAG

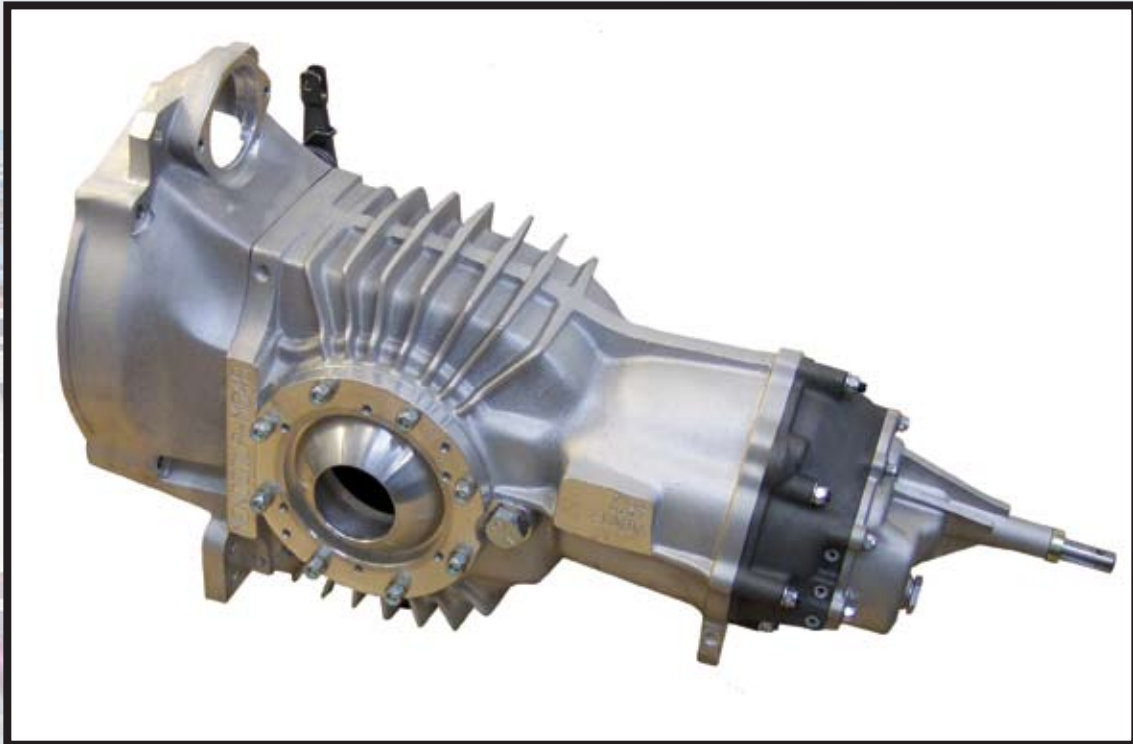

MD4-DRAG: COMPLETE TRANSMISSION

**Includes: 4.11 or 4.86 RING & PINION
CHOICE OF WEDDLE GEAR RATIOS 1st THRU 4th
SYNCROS OR PRO-SHIFT
SWING AXLE ALUMINUM SPOOL**



TOLL FREE 800-304-8726

MD4S-2D



MD4-E

4:86-5:14-10"

Ring & Pinion

002 Weddle 1st-4th gears

930 or 934 Drive flanges

Mid or rear engine

Oil included

MD4S-2D

4:86-5:14-5:43 10"

Ring & Pinion

Weddle 2D 1st-4th gears

930 or 934 Drive flanges

Mid or rear engine

Oil included

MD-5

4:86-5:14-5:43-10"

Ring & Pinion

Weddle 2D 1st-5th gears

930 or 934 Drive flanges

Mid or rear engine

Oil included

MENDEOLA

MD5

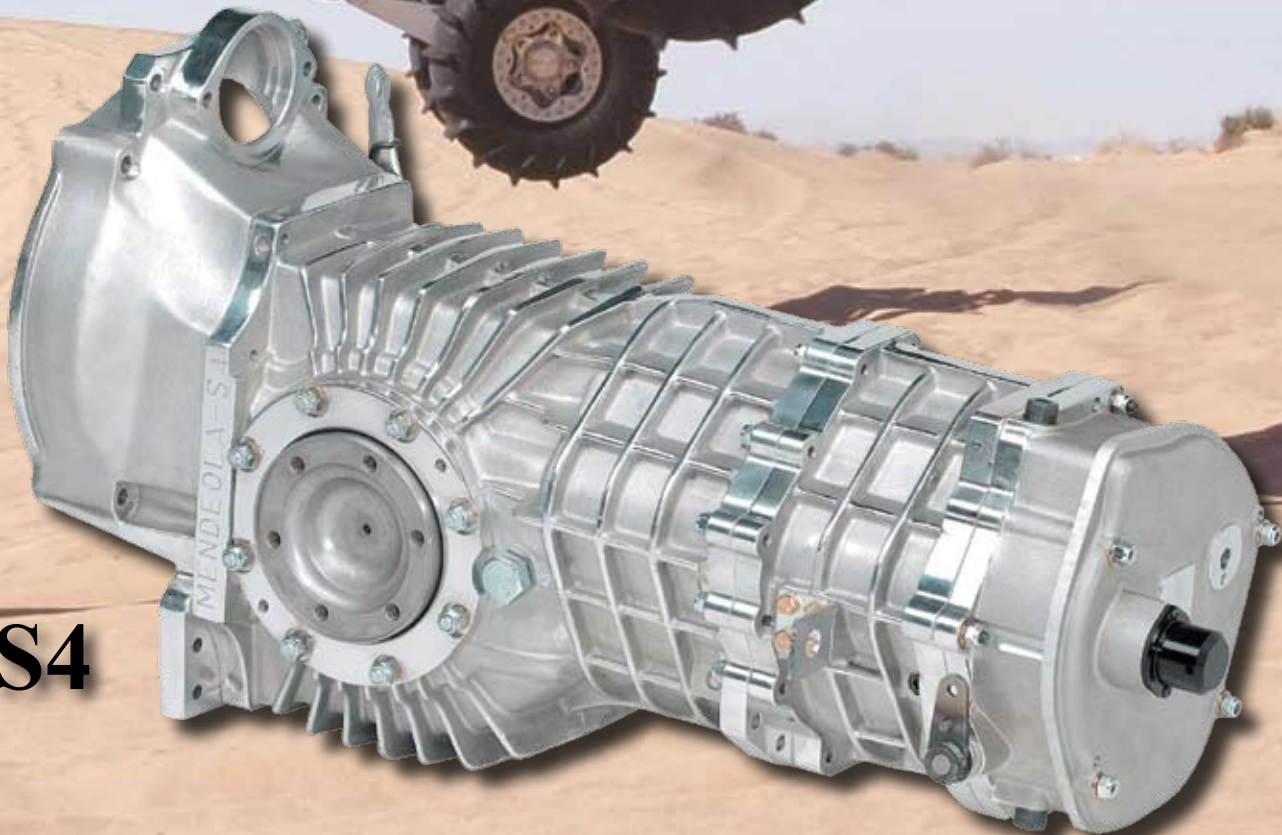
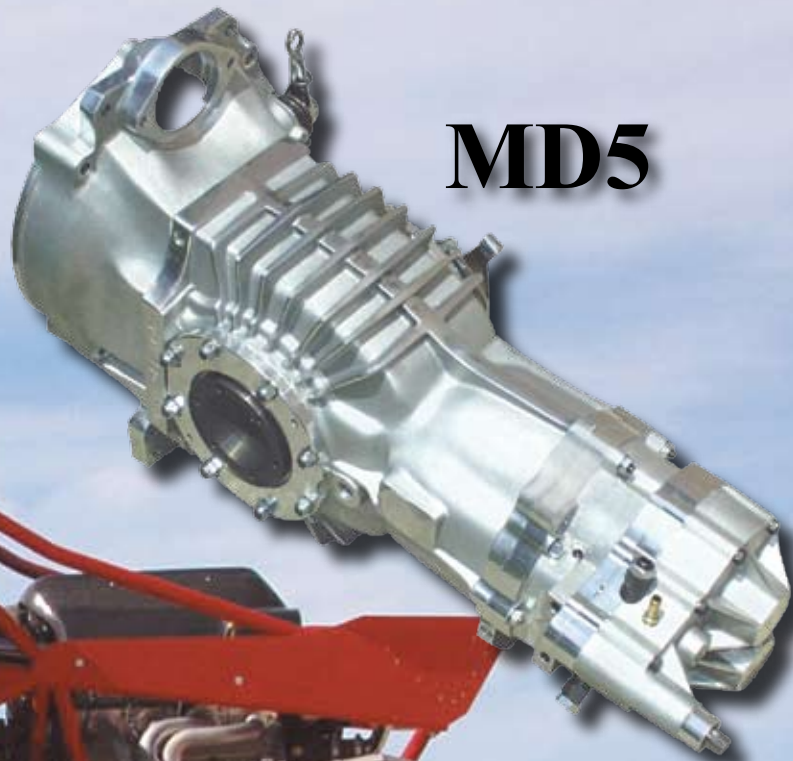

S4

TOLL FREE 800-304-8726



S4D



S4S & S5S

4:86-5:14-5:43-10"

Weddle Ring & Pinion

Weddle S4 or S5 gear set

934 Drive flanges

Mid or rear engine

Oil included

S4D & S5D

4:37, 4:63 or 4:88-11.5"

Ring & Pinion

Weddle S4 or S5 gear set

934 or Series 30 Drive flanges

Mid or rear engine

Oil included

WWW.RANCHOPERFORMANCETRANS.COM

BY



HD-4

4:86 13" inch Ring & Pinion

Mendeola 1st-4th gears

Series 30 drive flanges

Oil included

HD-4

TOLL FREE 800-304-8726

PARTS DEPARTMENT



HD 3RD GEAR SET



HD 4TH GEAR SET



**HD MAINSHAFT
1ST/2ND GEAR SET**



**SWING AXLE
SUPER DIFF**



**TYPE 1 & 2
SUPER DIFF**



QUAIFFE BUS DIFF



**ALUMINUM SPOOL
SWING AXLE**



**BUS IRS
ALUMINUM SPOOL**



**CHROMEMOLY IRS
DIFF COVERS**



**IRS ALUMINUM
SIDE COVER**



**SWING ALUMINUM
SIDE COVER**



**SUPER SPLINE
IRS STUBS**

PARTS DEPARTMENT



**388 RING & PINION
FOR TIMKEN BRG**



**RICHMOND TYPE 1
486 RING AND PINION**



**WEDDLE 091 457
RING AND PINION**



**2ND GEAR
PRO RING**

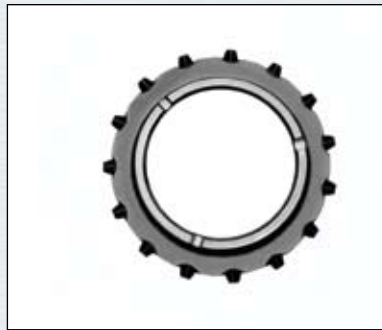

**3-4 SLICK SHIFT
RING**

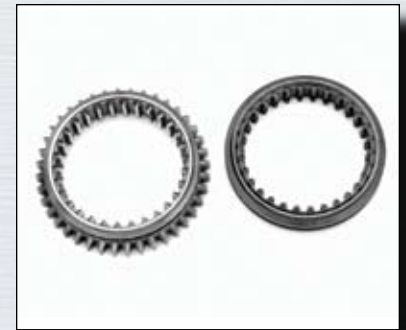

**TYPE 1
SLIDERS**



BERG 5-SPEED KIT



RHINO CASE



**MAGNESIUM CASE
GUSSETS**



**091 ALUMINUM
HOUSING**



**091 MID MOUNT
ALUMINUM HOUSING**



**BUS TO BUG GEAR
CARRIER HOUSING**

TOLL FREE 800-304-8726

PARTS DEPARTMENT



**CHROMEMOLY
PINION NUT**



**CHROMEMOLY
PINION RETAINER**

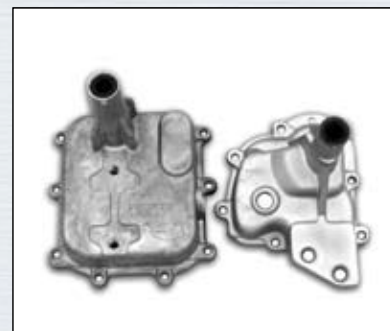

**TYPE 1 AND 2
NOSE CONES**



**HEAVY DUTY
SWING AXLE**



IRS AXLE



**CHROME TYPE 1
AXLE TUBE**



**TYPE 1 AND 930
CV JOINTS**



**TYPE 1 TO 930 CM
CV FLANGE/STUB**



**SWING AND IRS
AXLE BOOTS**



**STRAIGHT AXLE
CONVERSION "BUS"**



BUS MID MOUNT



**SWING ALUMINUM
BEARING RETAINER**

PARTS DEPARTMENT



**MENDEOLA
CROSS SHAFT**



**EARLY TO LATE T/O
BEARING CONVERSION**



KENNEDY CLUTCH



**SLAVE CYLINDER
SAVER**



**TYPE 1
TRANS STRAP**



**BUG TO BUS SOLID
MOUNT KIT**



EMPI SHIFTERS



**HARGETT
SEQUENTIAL SHIFTER**

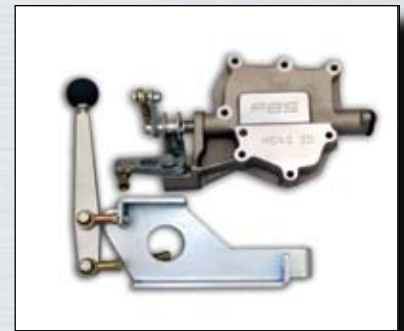

**PBS MID ENGINE
CABLE SHIFTER**



**STAINLESS STEEL
TRANS BREATHER**



**STOCK
REPLACEMENT PARTS**



**LAT HP SYNTHETIC
GEAR OIL**

TOLL FREE 800-304-8726

GEAR SETS AND RING & PINION RATIOS

113/ 002/ VW Gear Ratios

Mainshaft Sets

4:25x2:54	3:44x2:46	3:11x2:46	2:90x1:93
4:13x2:46	3:44x2:36	3:11x2:36	2:90x1:86
3:75x2:46	3:44x2:25	3:11x2:25	2:70x2:08
3:75x2:46	3:44x2:17	3:11x2:17	2:70x1:93
3:75x2:36	3:44x2:08	3:11x2:08	2:64x2:00
3:75x2:25	3:33x2:25	3:11x1:93	2:64x1:93
3:75x2:17	3:33x2:17	3:11x1:86	
3:75x2:08	3:33x2:08	2:90x2:17	
3:44x2:54	3:33x1:93	2:90x2:08	

rd Gear Sets

2:00	1:60	1:30
1:95	1:56	1:26
1:84	1:50	1:22
1:78	1:44	1:14
1:71	1:39	

4thGear Sets

1:67	1:39	1:18	0:93
1:60	1:35	1:14	0:89
1:56	1:30	1:09	0:77
1:50	1:26	1:04	0:70
1:44	1:22	1:00	
1:67	1:35		

Sportsman Moderate Duty Gears

Mainshafts

3:78Sx2:25	1:48	1:65	1:58	1:32	1:04
3:78Sx2:36	1:58	1:70	1:48	1:22	0:82
3:78Sx2:46			1:43	1:13	

3rd Gear Sets

4th Gear Sets

Gene Berg 5 Speed Mainshafts

3:75x2:25	3:30x2:21
-----------	-----------

091 Gears

091 Mainshafts

4:38x2:46	3:44x2:46	3:33x2:08	2:90x2:17
4:25x2:46	3:44x2:36	3:33x1:93	2:90x1:93
3:75x2:46	3:44x2:25	3:11x2:36	2:90x1:75
3:75x2:36	3:44x2:17	3:11x2:25	2:64x2:08
3:75x2:25	3:44x2:08	3:11x2:17	
3:75x2:17	3:33x2:25	3:11x2:08	
3:75x2:08	3:33x2:17	3:11x1:93	

091 3rd Gears

1:84	1:50	1:26
1:78	1:44	1:18
1:71	1:40	1:14
1:67	1:39	1:00
1:60	1:35	
1:56	1:30	

091 4th Gears

1:60	1:39	1:18	0:93
1:59	1:35	1:14	0:89
1:56	1:30	1:09	0:89
1:50	1:26	1:04	0:77
1:44	1:22	1:00	0:70

094 Vanagon Gears

094 4 Speed Mainshafts

4:13x2:25	3:75x2:25	3:44x2:17	3:75x2:36	3:44x2:25
-----------	-----------	-----------	-----------	-----------

094 3rd Gears

1:75	1:44	1:18
1:58	1:39	1:14
1:50	1:26	1:00

094 4th Gears

1:50	1:18	0:82
1:44	1:14	0:77
1:39	1:08	0:70
1:26	1:00	

VW Ring & Pinion Sets

Type 1 R&P Sets	002 Bus R&P Sets	091 R&P Sets	094 R&P Sets
4:86 Richmond	5:14 Weddle	5:83 VW used	4:86 Weddle
4:37 VW used	4:86 Weddle	5:50 VW used	4:57 Weddle
4:12 VW used	4:86 VW used	5:43 VW used	
3:88 VW used	4:86 US Gea	5:14 Weddle	094 5 Speed
3:88 VW Keyed	4:57 Weddle	4:86 Weddle	4:57 Weddle
3:44 US Gear	4:57 US Gear	4:57 Weddle	

Mendeola Ring & Pinion Sets

MD4E R&P

5:14 US Gear
4:86 US Gear
4:11 US Gear

MD4-2D R&P

5:86 Weddle
5:43 Weddle
5:14 Weddle
4:86 Weddle
4:86 US Gear
4:63 Weddle
4:57 Weddle
4:13 Weddle
4:11 US Gear

MD5 Speed

5:86 Weddle
5:43 Weddle
5:14 Weddle
4:86 Weddle
4:63 Weddle
4:13 Weddle
S4D S5D
4:63 Weddle
4:37 US Gear
4:88 Weddle

S4S/S5S

5:43 Weddle
5:13R Weddle
4:86 Weddle
4:63 Weddle
4:57 Weddle
HD
4:86 US Gear

MENDEOLA GEARS

MD4-E 4 Speed Mainshafts

4:25x2:54	3:44x2:46	3:11x2:46	2:90x1:93
4:13x2:46	3:44x2:36	3:11x2:36	2:90x1:86
3:75x2:46	3:44x2:25	3:11x2:25	2:70x2:08
3:75x2:46	3:44x2:17	3:11x2:17	2:70x1:93
3:75x2:36	3:44x2:08	3:11x2:08	2:64x2:00
3:75x2:25	3:33x2:25	3:11x1:93	2:64x1:93
3:75x2:17	3:33x2:17	3:11x1:86	
3:75x2:08	3:33x2:08	2:90x2:17	
3:44x2:54	3:33x1:93	2:90x2:08	

3rd Gear Sets

2:00	1:60	1:30
1:95	1:56	1:26
1:84	1:50	1:22
1:78	1:44	1:14
1:71	1:39	
1:67	1:35	

4thGear Sets

1:67	1:39	1:18	0:93
1:60	1:35	1:14	0:89
1:56	1:30	1:09	0:77
1:50	1:26	1:04	0:70
1:44	1:22	1:00	

GEARING SERVICE

MD4-2D Gear Sets

<u>Mainshafts</u>			<u>3rd Gear Sets</u>			
3:11x2:25	2:00x2:25	2:90x1:86	1:84	1:67	1:50	1:35 1:22
3:11x2:17	2:90x2:17	2:90x1:75	1:78	1:60	1:44	1:30 1:14
3:11x2:08	2:90x2:08	2:70x2:17	1:71	1:56	1:39	1:26
3:11x2:00	2:90x2:00	2:70x1:93				
3:11x1:93	2:90x1:93	2:64x1:86				
			<u>4th Gear Sets</u>			
			1:60	1:39	1:22	1:04 0:82
			1:56	1:35	1:18	1:00 0:77
			1:50	1:30	1:14	0:93 0:70
			1:44	1:26	1:09	0:89

MENDEOLA GEARS

MD5 Gear Sets

<u>Mainshafts</u>		<u>3rd Gear Sets</u>			<u>4th Gear Sets</u>		
3:11x2:25	2:90x2:00	1:84	1:56	1:30	1:56	1:31	1:09
3:11x2:17	2:90x1:93	1:78	1:50	1:26	1:50	1:26	1:04
3:11x2:08	2:90x1:86	1:71	1:44	1:22	1:44	1:22	1:00
3:11x2:00	2:64x1:93	1:67	1:39	1:14	1:39	1:18	
2:90x2:08		1:60	1:35		1:35	1:14	

5th Gear Sets

1:60	1:56	1:50	1:44	1:39	1:35
1:30	1:26	1:22	1:18	1:14	1:09
1:04	1:00	0:93	0:89	0:85	0:82
		0:77	0:70		

S4/S4D SEQUENTIAL 4-SPEED

<u>1st Gear Sets</u>	<u>2nd, 3rd, 4th Gear Sets</u>						
3:27	2:21	1:93	1:67	1:50	1:32	1:14	1:00
3:09	2:14	1:86	1:59	1:44	1:26	1:10	0:96
2:91	2:08	1:75	1:56	1:37	1:20	1:14	

S5/S5D SEQUENTIAL 5-SPEED

<u>1st Gear Sets</u>	<u>2nd Gear Sets</u>	<u>3rd, 4th, 5th, Gear Sets</u>				
3:27	2:21	1:93	1:59	1:37	1:14	0:96
3:09	2:14	1:89	1:56	1:32	1:10	0:89
2:91	2:08	1:75	1:50	1:26	1:04	
	1:93	1:67	1:44	1:20	1:00	

RANCHO PERFORMANCE TRANSAXLES specializes in all aspects of transaxle technology, development, fabrication, testing and service. We have established a reputation as the world's leader in this very specialized field based on our ability to produce and supply the strongest, most reliable transmissions available.

Our friendly, experienced, professionally trained technicians are on call to help you with any questions you may have regarding your current transaxle, a Rancho replacement or one of our many dedicated use assemblies. Additionally Rancho offers a comprehensive and extremely flexible list of in house services. From minor adjustments to major reconstructive surgery and custom machine work, it's all performed on site and on time.

- *Free estimates and inspection
- *Friendly one-on-one technical support
- *Free consultation to develop and design trans missions to fulfill customer's individual needs
- *Complete in-house machine shop service capability
- *Custom fabrication
- *Vintage transaxle repair and restoration
- *Rebuild to stock specifications
- *Mild street to all out drag strip high performance transmission fabrication and service
- *Custom designed Off Road transmission for play, race and severe duty applications
- *Super Sand transmissions for use with all engine applications including VW, Subaru, Mazda, Honda, North Star, LS-1 or power plant of your choice.
- *Massive Mendeola transaxles for use with engine output ratings to 1500 horsepower
- *Complete race shop capability

AT RANCHO CUSTOMER SATISFACTION IS JOB ONE. We are proud to serve you with the most knowledgeable, dedicated, customer friendly and accessible transmission service technicians in the industry. No matter what your needs give us a call and we'll help you choose the gear ratios and Ring & Pinion that's just right for your personal ride.

TOLL FREE 800-304-8726



WWW.RANCHOPERFORMANCETRANS.COM



TOLL FREE 800-304-8726



RANCHO

PERFORMANCE-TRANSAXLES

**THE SOURCE FOR ALL
YOUR TRANSAXLE NEEDS**

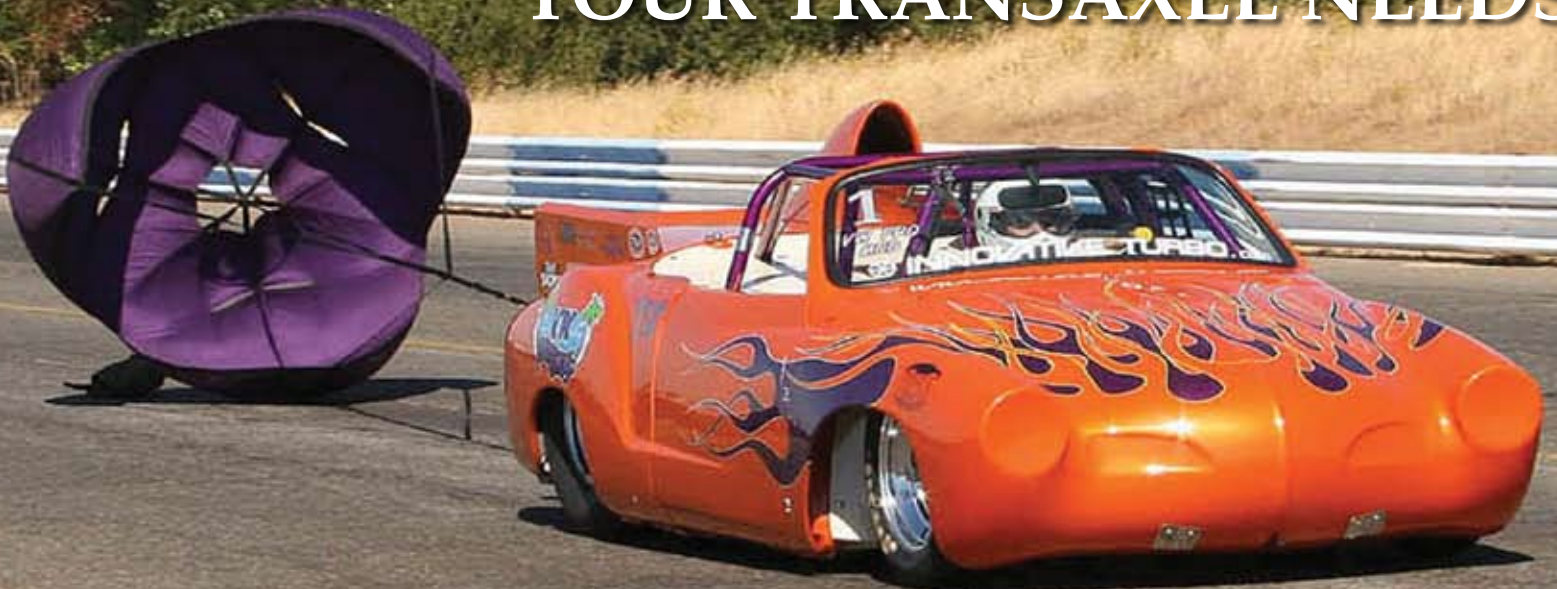

Rancho Performance Transaxles
1015 E. Elm Ave.
Fullerton, CA 92831
phone 714-680-6737
FAX 714-680-3110



WWW.RANCHOPERFORMANCETRANS.COM
800-304-8726